



755B

LOADER



**SAE Net
Horsepower**

140 hp
(104 kW)

**Drive
System**

Dual-path
hydrostatic

**Operating
Weight SAE**

36,150 lb.
(16,400 kg)

Model shown may include options

ENGINE

John Deere engineered and manufactured 6-cylinder diesel engine. Replaceable wet-type cylinder liners help ensure superior heat dissipation, longer engine life. High-strength alloy heads include replaceable valve seat inserts. The forged steel, 7-main bearing crankshaft is statically and dynamically balanced for smooth operation. Cast aluminum pistons reduce rod bearing loads and provide vital heat transfer; pistons are sprayed with cooling oil for longer life.

Engine: John Deere 6068T

Rated power at 2100 rpm	140 SAE net hp (104 kW)
	148 SAE gross hp (110 kW)
Turbocharger	standard
Cylinders	6
Displacement	414 cu. in. (6.785 L)
Fuel consumption, typical	3.5 to 5.0 gal./hr. (13.5 to 19 L/h)
Maximum net torque at 1300 rpm	420 lb.-ft. (570 Nm)
Lubrication	pressure system with full-flow filters
Air cleaner	dry type with restriction indicator
Electrical system	24-volt with 40-amp alternator
Cooling fan	blower

TRANSMISSION

Automatic, dual-path, hydrostatic drive provides infinitely variable speeds to 6.7 mph (10.8 km/h). The transmission's load sensing feature automatically adjusts speed and power to match changing load conditions. Each track is powered by a variable displacement piston pump and motor combination. The speed and direction of each track can be individually controlled.

TRAVEL SPEEDS

Forward and reverseinfinite to 6.7 mph (0 to 10.8 km/h)

FINAL DRIVES

Double-reduction, planetary final drives transfer torque loads over three gear sets instead of one. The final drives are mounted independently of the track frames to isolate them from shock loads for increased life and reliability.

BRAKES

Hydrostatic (dynamic) braking stops the crawler when the transmission control lever is moved to neutral. Wet, multi-disk parking brakes are automatically applied when the engine stops, when the neutral lever is placed in start position, or can be operator-applied by engaging the center brake pedal.

STEERING

Steering is done hydrostatically by varying track speed and/or direction. Depressing a pedal slows or varies the speed of the track, all the way to a stop if desired. Continuing to depress the pedal will cause the track to reverse for counterrotation. Hydrostatic steering eliminates the need for steering clutches and steering brakes, as well as the need for cross-steering when working on steep slopes.

HYDRAULICS

System	open center
Pressure	2500 psi (17 237 kPa)
Pump	gear
Flow at 2100 rpm	54 gpm (204 L/min.)

TRACKS

6-roller, 93.5-in. (2375 mm) track frame with front and rear track guides and sprocket guard. Dura-Trax™ undercarriage features deep-heat-treated, sealed and lubricated track links and through-hardened sealed and lubricated rollers for maximum wear resistance.

Standard Track

Two-bar grouser width	17 in. (432 mm)
Track shoes, each side	36
Ground contact area	3173 sq. in. (20 472 cm ²)
Ground pressure	11.4 psi (78.6 kPa)
Length of track on ground	93.5 in. (2375 mm)
Track gauge	66 in. (1676 mm)
Carrier roller, each side	1
Adjustment	hydraulic
Ground clearance, minimum	15.3 in. (389 mm)

Wide Track

Two-bar grouser width	21 in. (533 mm)
Track shoes, each side	36
Ground contact area	3927 sq. in. (25 336 cm ²)
Ground pressure	9.5 psi (65.5 kPa)
Length of track on ground	93.5 in. (2375 mm)
Track gauge	70 in. (1778 mm)
Carrier roller, each side	1
Adjustment	hydraulic
Ground clearance, minimum	15.3 in. (389 mm)

CAPACITIES

Fuel tank	73 gal. (276.3 L)
Cooling system	7 gal. (26.5 L)
Crankcase	18 qt. (17 L)
Crankcase, including filter	20 qt. (18.9 L)
Splitter drive	1.5 gal. (5.7 L)
Final drive each: 1st reduction	6.25 gal. (23.6 L)
2nd reduction	3.5 gal. (13.2 L)
Loader hydraulic system	37 gal. (140 L)
Hydrostatic drives	33 gal. (125 L)

OPERATING WEIGHTS

755B (with ROPS)	SAE
Standard track	36,150 lb. (16 400 kg)
Wide track	37,450 lb. (17 000 kg)

ENGINE

John Deere engineered and manufactured 6-cylinder diesel engine. Replaceable wet-type cylinder liners help ensure superior heat dissipation, longer engine life. High-strength alloy heads include replaceable valve seat inserts. The forged steel, 7-main bearing crankshaft is statically and dynamically balanced for smooth operation. Cast aluminum pistons reduce rod bearing loads and provide vital heat transfer; pistons are sprayed with cooling oil for longer life.

Engine: John Deere 6068T

Rated power at 2100 rpm	140 SAE net hp (104 kW)
	148 SAE gross hp (110 kW)
Turbocharger	standard
Cylinders	6
Displacement	414 cu. in. (6.785 L)
Fuel consumption, typical	3.5 to 5.0 gal./hr. (13.5 to 19 L/h)
Maximum net torque at 1300 rpm	420 lb.-ft. (570 Nm)
Lubrication	pressure system with full-flow filters
Air cleaner	dry type with restriction indicator
Electrical system	24-volt with 40-amp alternator
Cooling fan	blower

TRANSMISSION

Automatic, dual-path, hydrostatic drive provides infinitely variable speeds to 6.7 mph (10.8 km/h). The transmission's load sensing feature automatically adjusts speed and power to match changing load conditions. Each track is powered by a variable displacement piston pump and motor combination. The speed and direction of each track can be individually controlled.

TRAVEL SPEEDS

Forward and reverse infinite to 6.7 mph (0 to 10.8 km/h)

FINAL DRIVES

Double-reduction, planetary final drives transfer torque loads over three gear sets instead of one. The final drives are mounted independently of the track frames to isolate them from shock loads for increased life and reliability.

BRAKES

Hydrostatic (dynamic) braking stops the crawler when the transmission control lever is moved to neutral. Wet, multi-disk parking brakes are automatically applied when the engine stops, when the neutral lever is placed in start position, or can be operator-applied by engaging the center brake pedal.

STEERING

Steering is done hydrostatically by varying track speed and/or direction. Depressing a pedal slows or varies the speed of the track, all the way to a stop if desired. Continuing to depress the pedal will cause the track to reverse for counterrotation. Hydrostatic steering eliminates the need for steering clutches and steering brakes, as well as the need for cross-steering when working on steep slopes.

HYDRAULICS

System	open center
Pressure	2500 psi (17 237 kPa)
Pump	gear
Flow at 2100 rpm	54 gpm (204 L/min.)

TRACKS

6-roller, 93.5-in. (2375 mm) track frame with front and rear track guides and sprocket guard. Dura-Trax™ undercarriage features deep-heat-treated, sealed and lubricated track links and through-hardened sealed and lubricated rollers for maximum wear resistance.

Standard Track

Two-bar grouser width	17 in. (432 mm)
Track shoes, each side	36
Ground contact area	3173 sq. in. (20 472 cm ²)
Ground pressure	11.4 psi (78.6 kPa)
Length of track on ground	93.5 in. (2375 mm)
Track gauge	66 in. (1676 mm)
Carrier roller, each side	1
Adjustment	hydraulic
Ground clearance, minimum	15.3 in. (389 mm)

Wide Track

Two-bar grouser width	21 in. (533 mm)
Track shoes, each side	36
Ground contact area	3927 sq. in. (25 336 cm ²)
Ground pressure	9.5 psi (65.5 kPa)
Length of track on ground	93.5 in. (2375 mm)
Track gauge	70 in. (1778 mm)
Carrier roller, each side	1
Adjustment	hydraulic
Ground clearance, minimum	15.3 in. (389 mm)

CAPACITIES

Fuel tank	73 gal. (276.3 L)
Cooling system	7 gal. (26.5 L)
Crankcase	18 qt. (17 L)
Crankcase, including filter	20 qt. (18.9 L)
Splitter drive	1.5 gal. (5.7 L)
Final drive each: 1st reduction	6.25 gal. (23.6 L)
2nd reduction	3.5 gal. (13.2 L)
Loader hydraulic system	37 gal. (140 L)
Hydrostatic drives	33 gal. (125 L)

OPERATING WEIGHTS

755B (with ROPS)	SAE
Standard track	36,150 lb. (16 400 Kg)
Wide track	37,450 lb. (17 000 kg)

755B LOADER OPERATING INFORMATION

Bucket Type		General Purpose		
		Standard	Wide Track	Multipurpose
Capacity, heaped, SAE	cu. yd. m ³	2.25	2.5	2.0
		1.7	1.9	1.5
Capacity, struck, SAE	cu. yd. m ³	1.9	2.1	1.6
		1.5	1.6	1.2
Bucket width	in. mm	89.1	96.6	89.1
		2263	2454	2263
Bucket weight, without teeth	lb. kg	2110	2150	3520
		960	975	1597
Breakout force, SAE	lb. kN	27,500	27,150	27,000
		122	121	120
Tipping load, (with drawbar, four counterweights, ROPS)	lb. kg	25,340	26,120	23,930
		11 494	11 845	10 854
Raising time	sec.	5.86	5.86	5.86
Dumping time	sec.	1.27	1.27	1.27
Lowering time	sec.	3.23	3.23	3.23
Operating weight with ROPS canopy	lb. kg	36,150	37,450	37,560
		16 400	17 000	17 030
Operating weight with ROPS cab	lb. kg	36,550	37,850	37,960
		16 579	17 169	17 210

Adjustments to operating weights and tipping load for 2.25 cu. yd. (1.7 m³) bucket

ADJUSTMENTS TO OPERATING WEIGHTS

Add (+) or deduct (-) lb. (kg) as indicated for loader equipped with:		Wide Track	Operating Weight	Tipping Load
Cab	lb.	+ 400	+ 400	+ 440
	kg	+ 181	+ 181	+ 200
Bucket teeth, bolt-on	lb.	+ 338	+ 296	- 385
	kg	+ 153	+ 134	- 175
Bucket teeth, weld-on, flush mount	lb.	+ 206	+ 180	- 234
	kg	+ 93	+ 82	- 106
Air conditioner	lb.	+ 109	+ 109	+ 30
	kg	+ 49	+ 49	+ 14
Ripper (without drawbar and four counterweights)	lb.	- 106	- 106	+ 200
	kg	- 48	- 48	+ 91
Counterweight (each)	lb.	± 500	± 500	± 865
	kg	± 227	± 227	± 392

DIMENSIONS

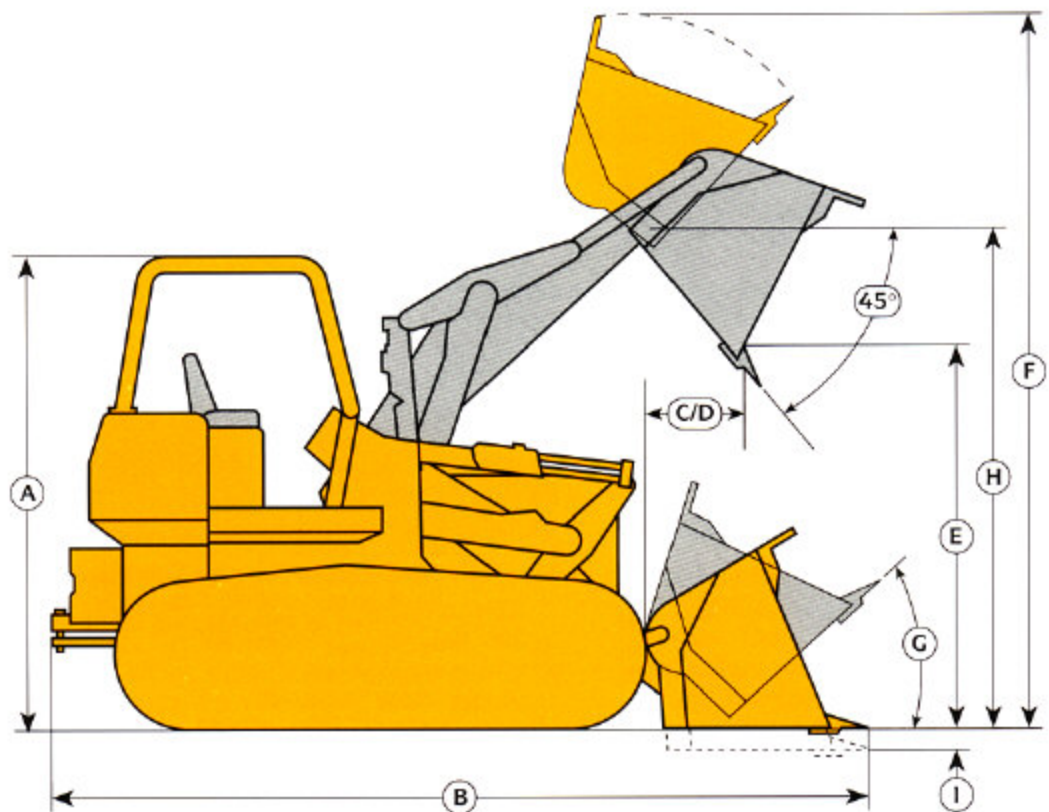

Key:

Bucket Type

	General Purpose		
	Standard	Wide-Track	Multipurpose
Capacity, heaped, SAE.....	2.25 cu. yd. (1.7 m ³)	2.5 cu. yd. (1.9 m ³)	2 cu. yd. (1.5 m ³)
A. Overall height	123.7 in. (3142 mm)	123.7 in. (3142 mm)	123.7 in. (3142 mm)
B. Overall length	222 in. (5639 mm)	222.5 in. (5652 mm)	223 in. (5664 mm)
C. Reach at maximum height (45° discharge).....	47 in. (1194 mm)	47.5 in. (1206 mm)	47.4 in. (1204 mm)
D. Reach at 84 in. (2134 mm) clearance (45° discharge)...	67 in. (1702 mm)	67.5 in. (1715 mm)	65 in. (1651 mm)
E. Dump clearance, maximum height (45° discharge).....	112 in. (2845 mm)	111.5 in. (2832 mm)	111.6 in. (2835 mm)
F. Maximum operating height	194 in. (4928 mm)	195 in. (4953 mm)	190 in. (4826 mm)
G. Rollback angle			
Concrete level.....	38 degrees	36 degrees	36 degrees
Carry position.....	45 degrees	45 degrees	45 degrees
H. Height to hinge pin.....	143 in. (3632 mm)	143 in. (3632 mm)	143 in. (3632 mm)
I. Digging depth	4.2 in. (107 mm)	4.2 in. (107 mm)	4.2 in. (107 mm)

ADDITIONAL STANDARD EQUIPMENT

Engine:	Less clutch disconnect
Air cleaner, dual-stage aspirated type	Transmission neutral lock with starter safety switch
Air cleaner restriction indicator	Transmission oil cooler
Precleaner	Hydraulics:
Fan guards	Two-spool hydraulic system
Engine coolant -34°F (-37°C)	"O" ring face seal connectors
Coolant recovery tank	Return to dig
Blower fan	Electrical System:
Trash resistant radiator	Master electrical disconnect switch
Oil to water engine oil cooler	Horn
Power Train:	Winch drive
Dual-path hydrostatic transmission	Reverse warning alarm

Operator's Station:	Front idler shields
Canopy (ROPS) with seat belt	Heavy-duty, hinged grille plate
Adjustable suspension seat	Lockable toolbox
Adjustable armrests	Muffler, self-draining, eliminating external rain cap
Push button starting	Tilt cylinder hose protection
Key switch	Vandal protection
Hourmeter	Tracks:
Voltmeter	Dura-Trax sealed and lubricated chain
Interior-mounted rearview mirror	17-in. (432 mm) grouser shoes
Overall Vehicle:	
Boom safety lock pin	
Heavy-duty bottom guards	
Perforated engine side shields	
Less bucket	

OPTIONAL OR SPECIAL EQUIPMENT WITH WEIGHTS

(Add these weights to SAE standard equipment operating weights to obtain total operating weights.)

	lb.	kg		lb.	kg
Batteries (two 12-volt) cold-cranking capacity @ 0°F (-18°C) 925 amps, reserve capacity			Selector valve and lines to rear for ripper and MP bucket	10	5
180 min. each	18	8	Lights, two front, one rear, halogen	7	3
Bucket teeth, bolt-on	296	134	Oil sampling kit	2	1
Cab with pressurizer, heater and 42-amp alternator	400	182	Pedal extensions	12	5
Air conditioner	109	49	Protection items:		
Windshield wiper	3	1	Brush screens, heavy-duty, third post-type	130	59
Cold weather starting aid	2	1	Brush screens, regular-duty	72	33
Disconnect clutch	20	9	Limb risers and overhead exhaust	265	120
Drawbar	198	90	Rear screen	50	23
Engine coolant heater	2	1	Tank protection	650	295
Fan, reversible	38	17	Radiator sand shield	25	11
Fire extinguisher	6	3	Ripper, parallelogram type	2400	1089
Hydraulics:			Rock guard, center-section	178	81
Lines for front-mounted equipment	6	3	Tracks:		
Lines for rear-mounted equipment	4	2	Dura-Trax sealed and lubricated chain with split master link and 21-in. (533 mm) two-bar grouser shoes	0	0

THE JDAvantEDGE

JDAvantEdge is a wealth of support programs, parts systems and dealer resources, all designed to give you the edge. This package of special benefits is a major reason why John Deere offers the "best value" for your equipment dollar.

Best parts support – Twelve regional parts depots in North America and others around the world put parts support near your job no matter where in the world it is.

A computerized FLASH™ parts locating system linking these depots to dealerships can find out-of-stock parts in a hurry and get them into your hands fast. Usually within 24 hours.

Best service backup – Dealer service technicians are regularly schooled, at our modern facility in Davenport, Iowa, or by professionals in the field, to diagnose quickly and repair efficiently.

If they're stumped, a phone call to DTAC (Dealer Technical Assistance Center) puts them in touch with a staff of pros at the factory who help them find a solution quickly.

Best dealers – Your John Deere dealer is an important contributor to the JDAvantEdge. He or she is committed to being the best equipment supplier you can work with.

This is a dollars-and-cents commitment in parts inventory, in service facilities, in field service trucks. It's a sweat-and-blood commitment in dedicated, skilled and highly trained and motivated personnel in each and every department at the dealership.

But what sets John Deere dealers apart from all the rest is something more, a factor somewhat difficult to measure ... a caring attitude, and a sincere desire to be the best at meeting the needs of each individual customer.

John Deere Finance Plans – Whether you rent, lease or buy John Deere equipment, your dealer can explain the John Deere options available. One-stop options that let you free up operating capital, keep other lines of credit open. More solid benefits of the JDAvantEdge.

Best protection – In addition to the new equipment warranty that meets or exceeds the competition, SECURE® extended coverage, an optional service product for John Deere equipment, is available for repair coverage after the warranty concludes. Full machine or power train coverage is available for a variety of time periods to meet your needs. Consult your dealer for availability and details.

Net engine power is with standard equipment including air cleaner, exhaust system, alternator, and cooling fan, at standard conditions per SAE J1349 and DIN 6270B, using No. 2-D fuel at 35 API gravity. No derating is required up to 10,000 feet (3050 m) altitude. Gross power is without cooling fan.

Specifications and design subject to change without notice. Wherever applicable, specifications are in accordance with SAE standards. Except where otherwise noted, these specifications are based on a unit with 2.25 cu. yd. (1.7 m³) bucket with teeth, rollover protective canopy, four counterweights, full fuel tank, 175-lb. (79 kg) operator and standard equipment.

