

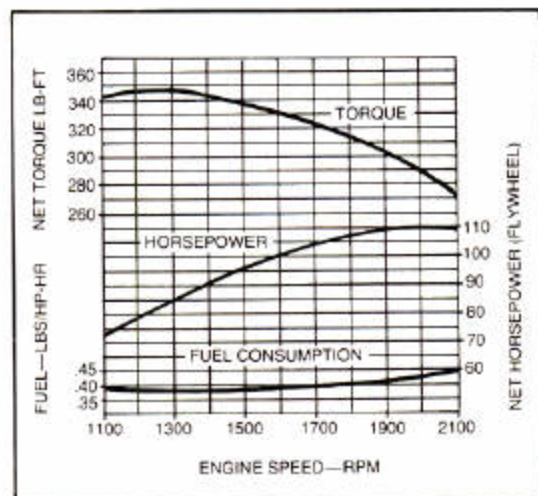

655 LOADER



ENGINE PERFORMANCE



FEATURES

- 110 SAE net hp (82 kW)
- Dual-Path automatic hydrostatic drive with infinite speeds up to 6.5 mph (10.5 km/h)
- Single lever for speed and direction control
- Pedals for independent track control steering
- Counterrotating tracks
- No steering clutches or steering brakes
- Automatically engaged parking brake
- Sealed track rollers and idlers
- Sealed, counterbored track links and bushings
- Sealed loader linkage
- Single-lever loader control w/float position and bucket return-to-dig
- Dual-stage aspirated air cleaner
- Perforated engine side shields
- Designed for quietness
- Roll-over protective structure (ROPS)

ADD VERSATILITY WITH:

- Winch
- Ripper
- Multipurpose bucket

655 LOADER SPECIFICATIONS

(Specifications and design subject to change without notice. Wherever applicable, specifications are in accordance with ICED and SAE Standards. Except where otherwise noted, these specifications are based on a unit equipped with 2 cu. yd. (1.53 m³) bucket with teeth, roll-over protective canopy, four counterweights, and standard equipment.)

Power (@ 2100 rpm):	SAE	DIN
Gross	122 hp (91 kW)	
Net	110 hp (82 kW)	111.5 PS

Net engine flywheel power is for an engine equipped with fan, air cleaner, water pump, lubricating oil pump, alternator and muffler. The gross engine power is without fan. Flywheel power ratings are under SAE standard conditions of 500-ft. altitude and 85° F. temperature, and DIN 6270 conditions (non-corrected). No derating is required up to 10,000 feet (3000 m) altitude.

Engine: John Deere 6-cylinder turbocharged diesel, valve-in-head, 4-stroke cycle.

Bore and stroke	4.19×5 in. (106.4×127 mm)
Piston displacement	414 cu. in. (6.785 L)
Compression ratio	16.2 to 1
Maximum torque @ 1300 rpm	345 lb-ft (468 Nm) (47.7 kg-m)
NACC or AMA (U.S. Tax) horsepower	42
Lubrication	Pressure system w/full flow filters
Main bearings	7
Cooling	Pressurized w/thermostat and controlled bypass
Fan	Blower
Dual-stage aspirated air cleaner w/restriction indicator	Dry
Electrical system	24 volt w/alternator
Batteries (2 12-volt)	Reserve capacity: 180 minutes each

Transmission:

Cold weather starting	Disconnect clutch completely disengages hydrostatic drive and all hydraulics.
Splitter drive	Pressure-lubricated helical gears drive both hydrostatic transmissions, main hydraulic pump, winch drive shaft and auxiliary pump drive.
Drive	Dual-Path, fully automatic, infinitely variable hydrostatic transmissions.
Speeds	Infinite from 0 to 6.5 mph (0 to 10.5 km/h) forward or reverse.
Control	Single-lever, variable speed, forward and reverse.

Steering:

Fully modulated, infinitely variable pedal steering for live power turns and counterrotation. No need for steering clutches or steering brakes.

Brakes:

Service	Hydrostatic
Parking	Wet-disk brakes are automatically applied when engine is stopped, or manually applied with center foot pedal during normal operation.

Hydraulic System: Open-center

Control	Single-lever bucket control with automatic bucket positioner and float position. Three-function valve.
Pump	Vane, 55 gpm (3.47 L/s) @ rated engine speed
Pressure	2250 psi (15 514 kPa) (158.2 kg/cm ²)
Oil lines	Seamless steel tubing; double-wire-braid hose
Filter	10 micron filter in return line w/bypass

Hydraulic Cylinders:	Bore	Stroke
Boom (2)	5.50 in. (140 mm)	32 in. (813 mm)
Bucket (2)	4.50 in. (114 mm)	21.52 in. (547 mm)
Cylinder rods	Ground, heat-treated, chrome-plated, polished	
Boom cylinder rods	3.75 in. (95 mm) dia.	
Bucket cylinder rods	2.25 in. (57 mm) dia.	

Tracks (6-roller track frame with front and rear track guides and sprocket guard):

Two bar grouser	15 in. (381 mm)
Track shoes, each side	40
Ground contact area	2724 sq. in. (17 575 cm ²)
Ground pressure	11.8 psi (81.4 kPa) (0.830 kg/cm ²)
Length of track on ground	90.8 in. (2.31 m)
Track gauge	64 in. (1.63 m)
Carrier roller	1 each side
Adjustment	Hydraulic
Minimum ground clearance	15.3 in. (389 mm)

Capacities:

	U.S.	Imp.	Liters
Cooling system	7 gal.	5.8 gal.	26.5
Fuel tank	73 gal.	60.8 gal.	276.3
Crankcase	18 qt.	15.0 qt.	17.0
Crankcase, including filter	20 qt.	16.7 qt.	18.9
Splitter drive	1.5 gal.	1.3 gal.	5.7
Final drive each: 1st reduction	5.375 gal.	4.5 gal.	20.3
2nd reduction	3.5 gal.	2.9 gal.	13.2
Loader hydraulic system	37 gal.	30.8 gal.	140.1
Hydrostatic drives	33 gal.	27.5 gal.	124.9

Additional Standard Equipment:

Enclosed alternator w/solid-state regulator
Bottom guards
Suspension seat w/armrests
Key switch
Pushbutton starting
Electric hourmeter
Cigaret lighter
Vandal protection
Boom safety lock pin
Muffler
Either starting aid
Front idler shields
Master electrical disconnect switch
Toolbox
Transmission neutral lock w/starter safety switch
Horn
Air cleaner restriction indicator
ROPS canopy w/seat belt
Radiator sand shield

SAE Operating Weight w/ROPS 32,005 lb. (14 517 kg)

655 LOADER OPERATING INFORMATION

OPERATING INFORMATION	BUCKET	
	General Purpose	Multipurpose
Capacity, Heaped, SAE	2 cu. yd. (1.53 m ³)	1¾ cu. yd. (1.34 m ³)
Capacity, struck, SAE	1.67 cu. yd. (1.28 m ³)	1.38 cu. yd. (1.06 m ³)
Bucket width	82.5 in. (2.1 m)	83.84 in. (2.13 m)
Bucket weight	1550 lb. (703 kg)	2485 lb. (1127 kg)
SAE breakout force	25,310 lb. (113 kN) (11 480 kg)	23,060 lb. (103 kN) (10 460 kg)
SAE tipping load (w/drawbar and four counterweights)	19,500 lb. (8845 kg)	18,565 lb. (8421 kg)
Raising time	5.86 sec.	5.86 sec.
Dumping time	1.27 sec.	1.27 sec.
Lowering time	3.23 sec.	3.23 sec.
SAE operating weight w/ROPS canopy	32,005 lb. (14 517 kg)	32,940 lb. (14,941 kg)

Adjustments to operating weights and tipping loads:

Add (+) or deduct (-) lb. (kg) as indicated for loader equipped with:	Loader Operating Weight	Tipping Load
Cab	+ 740 lb. (336 kg)	+ 814 lb. (369 kg)
Bucket teeth	+ 151 lb. (68 kg)	- 198 lb. (90 kg)
Air conditioning	+ 65 lb. (29 kg)	0
Ripper	+ 2400 lb. (1089 kg)	+ 4516 lb. (2048 kg)
Multipurpose bucket	+ 935 lb. (424 kg)	- 935 lb. (424 kg)
Counterweight (each)	+ or - 500 lb. (227 kg)	+ or - 865 lb. (392 kg)

Special Equipment:

- Oil sampling test kit
- Bucket teeth, bolt-on or flush-mount weld-on
- Hydraulics for rear-mounted equipment
- Hydraulics for front-mounted equipment
- Selector valve for ripper and multipurpose bucket
- Protection package:
 - Limb risers for ROPS canopy
 - Brush screens for operator's compartment
 - Rear bumper
 - Tank guards
- Fire extinguisher
- Front pull hook
- Cab w/windshield wipers, pressurizer and heater
- Air conditioner
- Windshield washer
- Engine coolant heater
- Backup alarm
- Lexan® windshield w/wiper
- Lexan® windows for cab
- Rock guard, center section

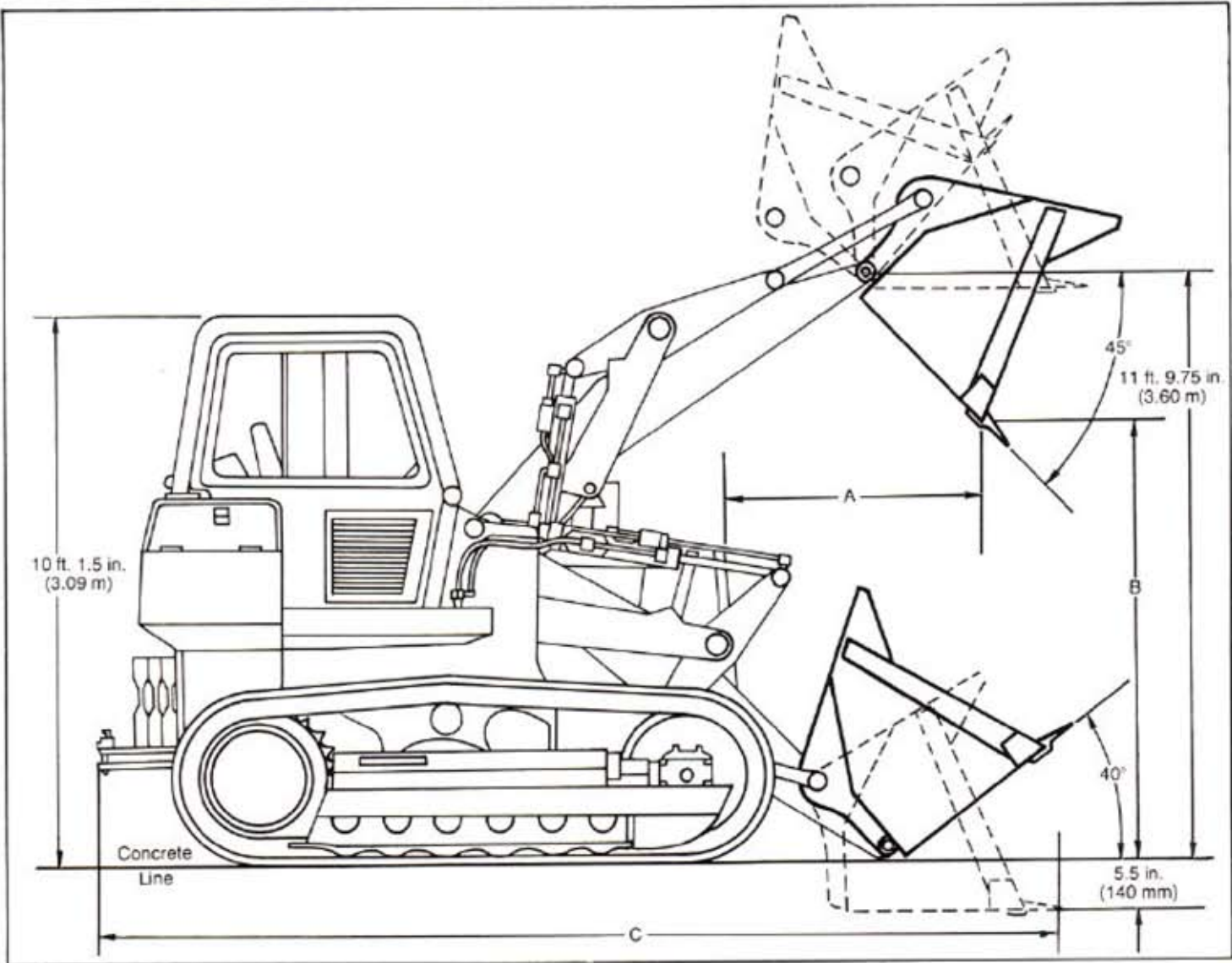

BUCKET CAPACITIES	DIMENSIONS		
	A	B	C
2 cu. yd. bucket (1.68 m ³)	47.5 in. (1207 mm)	9 ft. 3 in. (2.82 m)	18 ft. 3 in. (5.56 m)
1½ cu. yd. (1.34 m ³) multipurpose	53 in. (1.35 m)	9 ft. 4.5 in. (2.86 m)	18 ft. 6.75 (5.66 m)

