



350C/6300 BULLDOZER

FEATURES

- 42 SAE net hp (31.3 kW)
- Hydraulic track adjustment
- Self-adjusting, oil-cooled steering clutches and brakes
- Walk-through compartment
- Hydraulic direction reverser
- Manual angle
- Manual tilt
- Vandal protection
- Roll-over protective structure (ROPS)

ADD VERSATILITY WITH:

- Winch
- Fairlead and drawbar
- Integral log arch
- Ripper
- Backhoe
- Sideboom



ENGINE PERFORMANCE

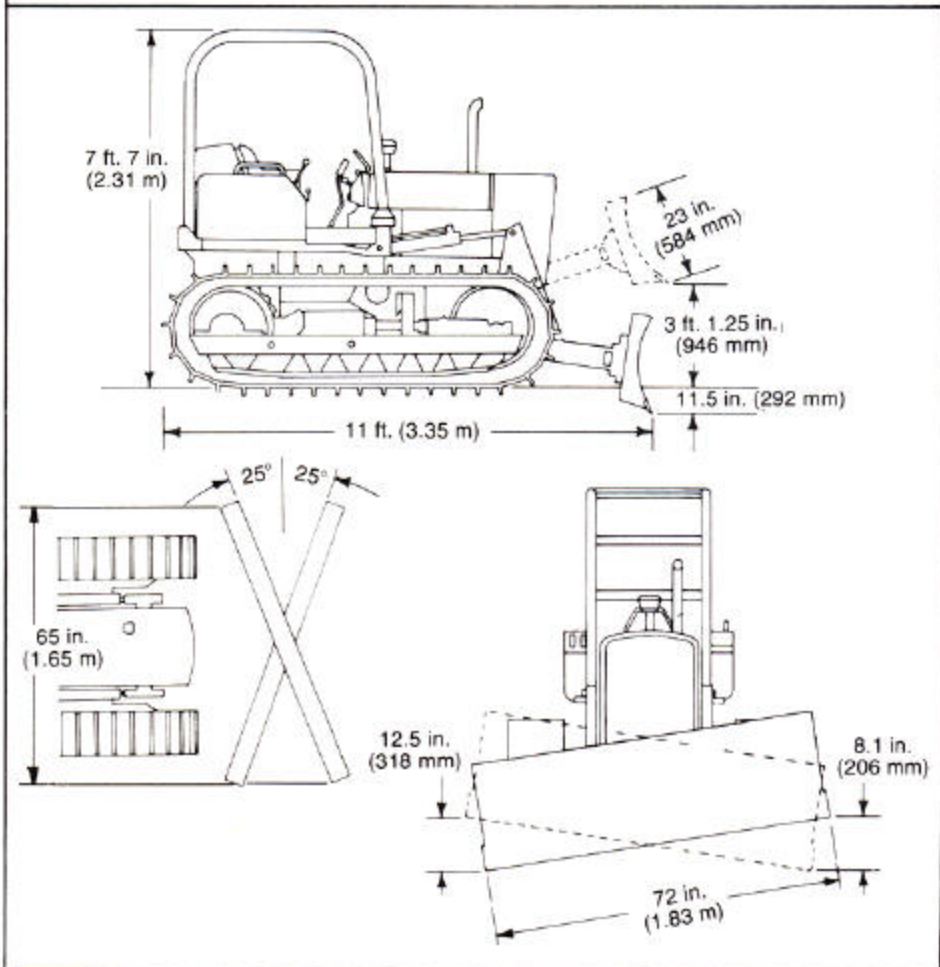
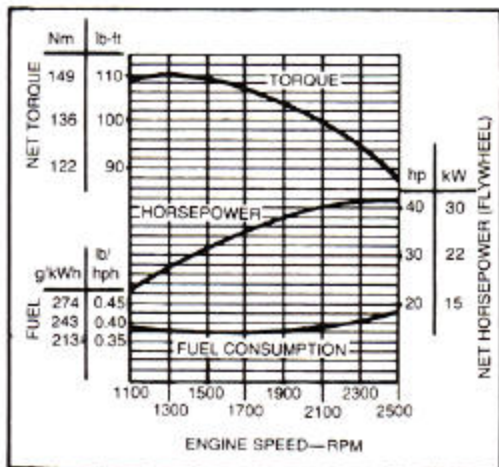

350C/6300 BULLDOZER SPECIFICATIONS

(Specifications and design subject to change without notice. Wherever applicable, specifications and design are in accordance with ICED and SAE Standards. Except where otherwise noted, these specifications are based on a unit with diesel engine, roll-over protective structure, full fuel tank, 175-lb. (79 kg) operator and standard equipment).

Power (@ 2500 engine rpm):	SAE	DIN
Gross	46 hp (34.3 kW)	
Net	42 hp (31.3 kW)	43.3 hp (31.8 kW)
Drawbar	31.2 hp (23.3 kW)	31.6 hp (23.2 kW)

Net engine flywheel power is for an engine equipped with fan, air cleaner, water pump, lubricating oil pump, fuel pump, alternator, and muffler. Gross engine power is without fan. Flywheel power ratings are under SAE standard conditions of 500-ft. (150 m) altitude and 85° F (29.5°C) temperature and DIN 6270 standard conditions of 760 mm Hg barometer (sea level) and 20°C temperature.

Engine: John Deere 3-cylinder diesel, valve-in-head, 4-stroke cycle

Bore and stroke	4.02×4.33 in. (102×110 mm)
Displacement	164 cu. in. (2.688 L)
Compression ratio	16.2 to 1
Maximum torque @ 1300 rpm	110 lb-ft (149 Nm) (15.2 kg-m)
Torque rise	25 percent
NACC or AMA (U.S. Tax) horsepower	17.88
Main bearings	4
Lubrication	Pressure system w/full-flow filter
Cooling	Pressurized w/thermostat and fixed bypass
Fan	Blower
Air cleaner w/restriction indicator	Dry, dual stage
Electrical system	12-volt w/alternator
Battery (12 volt)	Reserve capacity: 180 minutes

Transmission Selective sliding gear

Hydraulic Direction Reverser Multiple-disk oil clutches

Gear	Travel Speeds		Maximum Drawbar Pull (with adequate weight and traction)		
	mph	km/h	lb.	kN	kg
1st	1.4	2.3	10,850	48.63	4841
2nd	1.9	3.1	7,100	31.82	3223
3rd	3.3	5.3	3,650	16.36	1657
4th	6.5	10.4	1,550	6.95	704

Steering:

Steering clutches and brakes are controlled by a single lever for each track. A pedal provides braking and lockdown for parking.

Clutches Oil-cooled, hydraulically-actuated multiple-disk; 9-in. (228 mm) disks; 16 friction surfaces per clutch.

Brakes Self-adjusting, self-energizing, oil-cooled contracting band with bonded lining.

Hydraulic System:

Control Single-lever, double hydraulic system

Pump Gear, 15 or 23 gpm (0.9 or 1.45 L/s)

Pressure 1,750 psi (12 066 kPa) (123.0 kg/cm²)

Hydraulic Cylinders:

	Bore	Stroke
Two, double-acting	3-in. (76 mm)	12.125 in. (308 mm)
Cylinder rods	Ground, heat-treated, chrome-plated, polished	
Cylinder pivot pins	Hardened steel (replaceable bushings)	

Tracks: (5-roller track frames w/rock guards):

Grouser	14 in. (356 mm)
Track shoes, each side	36
Ground contact area	1,939 sq. in. (12 510 cm ²)
Ground pressure	5.3 psi (36.5 kPa) (0.373 kg/cm ²)
Length of track on ground	69.3 in. (1.76 m)
Track gauge, standard	48 in. (1.22 m)
Carrier roller	1
Adjustment	Hydraulic
Clearance at rear crossbar	13.25 in. (337 mm)

Blade: Reinforced, box-welded

Cutting edge	3-piece, reversible, replaceable
Center section	0.5 in. (12.7 mm)
End bits	0.625 in. (15.8 mm)

Capacities:

	U.S.	Liters
Cooling system	3.25 gal.	12.3
Fuel tank	22 gal.	83.0
Crankcase, including filter	9 qt.	8.5
Transmission, steering clutch housings and final drives	10 gal.	38.0
Direction reverser	12 qt.	11.3
Hydraulic reservoir	6.4 gal.	24.2
Hydraulic system	9 gal.	34.1

Additional Standard Equipment:

Transistorized voltage regulator
 Front/rear bottom guard
 Front hitch
 Deluxe cushion seat w/arm rests
 Key switch w/push-button safety start
 Precleaner
 Electric hourmeter
 Cigaret lighter
 Vandal protection
 Engine side shields
 Outer sprocket shields
 Lights
 Tachometer
 Ether starting aid
 ROPS w/canopy and seat belt
 Horn
 Master electrical disconnect switch

SAE Operating Weight w/ROPS 10,150 lb. (4605 kg)

Special Equipment

Spark-arresting muffler
 PTO (540 rpm)
 Swinging drawbar
 Inner sprocket shields
 Auxiliary control valve
 Remote cylinder and lines
 Three-point hitch
 Trash-resistant radiator
 10-in. (254 mm) rubber shoes
 14-in. (356 mm) open-center grouser shoes
 Dozer counterweight
 Winch drive
 Two batteries
 Cab (includes ROPS)
 Limb risers and overhead exhaust
 Brush screens

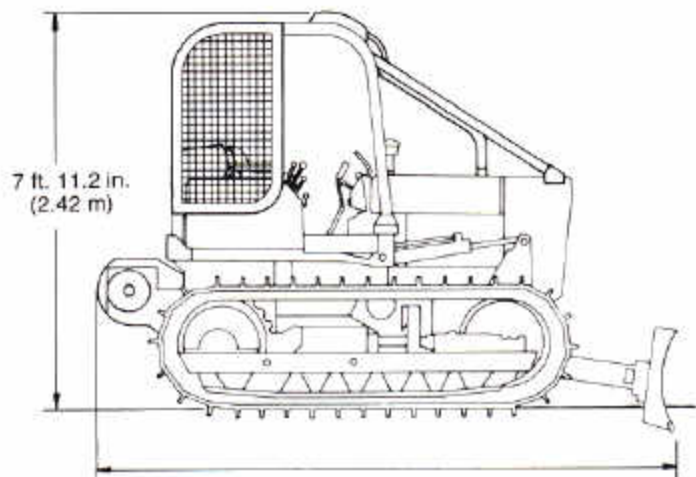

Limb risers and brush-protection assembly for roll-over protective structure