



850B

DOZER



**SAE Net
Horsepower**

165 hp
(123 kW)

**Drive
System**

Dual-path
hydrostatic

**Operating
Weight SAE**

37,915 lb.
(17,198 kg)

Model shown may include options

ENGINE

John Deere engineered and manufactured 6-cylinder diesel engine. Replaceable wet-type cylinder liners help ensure superior heat dissipation, longer engine life. High-strength alloy heads include replaceable valve seat inserts. The forged steel, 7-main bearing crankshaft is statically and dynamically balanced for smooth operation. Cast aluminum pistons reduce rod bearing loads and provide vital heat transfer; pistons are sprayed with cooling oil for longer life.

Engine: John Deere 6466A	
Rated power at 1800 rpm	165 SAE net hp (123 kW)
	175 SAE gross hp (131 kW)
Turbocharger	aftercooled
Cylinders	6
Displacement	466 cu. in. (7.638 L)
Fuel consumption, typical	4.3 to 6.4 gal/hr (16.3 to 24.2 L/h)
Maximum net torque at 1200 rpm	578 lb-ft (784 Nm)
Lubrication	pressure system with full-flow filters
Air cleaner	dry type with restriction indicator
Electrical system	24-volt with 40-amp alternator
Cooling fan	blower

TRANSMISSION

Automatic, dual-path, hydrostatic drive provides infinitely variable speeds to 6.5 mph (10.5 km/h). The transmission's load sensing feature automatically adjusts speed and power to match changing load conditions. Each track is powered by a variable displacement piston pump and motor combination. The speed and direction of each track can be individually controlled.

TRAVEL SPEEDS

Forward and reverse	infinite to 6.5 mph (0 to 10.5 km/h)
---------------------	--------------------------------------

FINAL DRIVES

Double-reduction, planetary final drives transfer torque loads over three gear sets instead of one. The final drives are mounted independent of the track frames to isolate them from shock loads for increased life and reliability.

BRAKES

Hydrostatic (dynamic) braking stops the crawler when the transmission control lever is moved to neutral. Wet, multi-disk parking brakes are automatically applied when the engine stops, or can be operator-applied by engaging the center brake pedal.

STEERING

Steering is done hydrostatically by varying track speed and/or direction. Pedal steering is standard; lever steering is available. Depressing a pedal slows or varies the speed of the track, all the way to a stop if desired. Continuing to depress the pedal will cause the track to reverse for counter-rotation. Hydrostatic steering eliminates the need for steering clutches and steering brakes, as well as the need for cross-steering when working on steep slopes.

HYDRAULICS

System	open center
Pressure	2250 psi (15 514 kPa)
Pump	vane
Flow at 1800 rpm	44 gpm (166 L/min)

TRACKS

6-roller, 95-in. (2413 mm) track frame with front and rear track guides and sprocket guard. Dura-Trax™ undercarriage features deep-heat-treated sealed and lubricated track links and through-hardened sealed and lubricated rollers for maximum wear resistance.

Grouser	24 in. (610 mm)
Shoes, each side	37
Ground contact area with 24-in. (610 mm) shoes	4560 sq. in. (29 419 cm ²)
Ground pressure	8.3 psi (57.2 kPa)
Ground clearance, minimum	16.4 in. (417 mm)
Length of track on ground	95 in. (2413 mm)
Track gauge, standard	74 in. (1880 mm)
Oscillation	10 in. (254 mm)
Carrier rollers each side	2
Adjustment	hydraulic

CAPACITIES

Fuel tank	82 gal. (310.4 L)
Cooling system	9 gal. (34 L)
Crankcase	32 qt. (30.3 L)
Crankcase, including filter	34 qt. (32.2 L)
Splitter drive	1.5 gal. (5.7 L)
Final drive each: Inner compartment	5.5 gal. (20.8 L)
Outer compartment	3.5 gal. (13.2 L)
Hydraulic system	35 gal. (132.5 L)
Hydrostatic drives	40 gal. (151.4 L)

OPERATING WEIGHT

850B	37,915 lb. (17 198 kg)
------	------------------------



OPERATOR'S STATION

The 850B features a roomy, walk-through platform design. Controls are logically located, with transmission and throttle levers on your left and hydraulic levers on the right. Steering is done with short-throw levers or easy-to-push pedals. Easy-to-read, color-coded, non-glare gauges are placed well within your forward field of vision.



EASY SERVICING

Convenient, exterior-mounted sight gauges provide a quick reading of hydrostatic and hydraulic fluid levels. The engine fluid and air filter restriction indicators are visible through doors on top of the hood. The dual-stage, dry-type aspirated air cleaner nearly triples filter life, as well as eliminating daily servicing.



ISOLATED FINAL DRIVES

The double-reduction planetary final drives transfer torque loads over three gear sets instead of one. They're mounted independent of the track frames. This keeps shock loads away from the final drives and other vital drivetrain components. Modular design makes servicing easy.

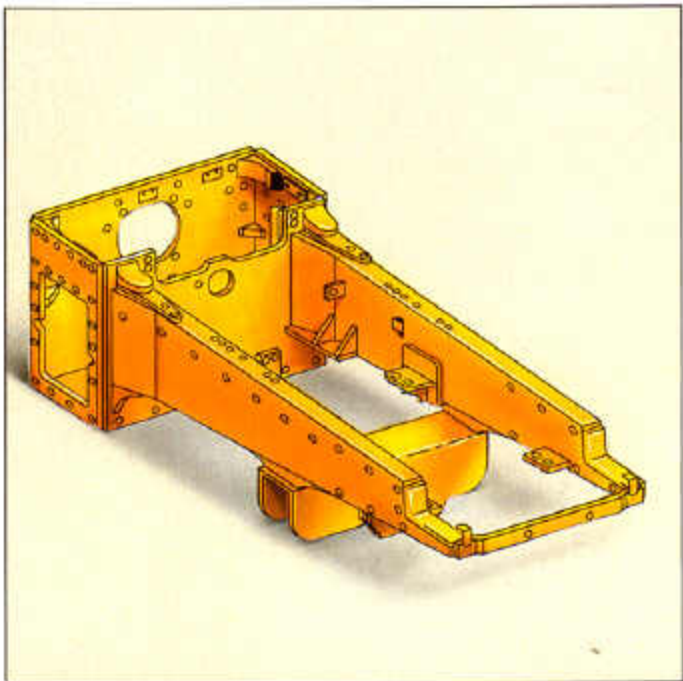

MAINFRAME

All drivetrain components are mounted independently to the massive unitized mainframe where they're isolated from working stress and shock loads. Drivetrain components can be removed independently of one another for faster repairs and reduced downtime.

HYDROSTATIC DRIVETRAIN

Dual-path hydrostatic drive provides many advantages over mechanical crawler drivetrains in the areas of machine performance and reliability.

Live power turns. Both tracks remain fully powered during turns. This affords greater maneuverability with larger loads and less ground disturbance. This feature also provides improved capability for working on soft ground, as well as the ability to counterbalance blade-corner loads when benching, ditching or backfilling.

Counterrotation. Separate control allows the two transmissions to be driven in opposite directions, permitting spot turns with excellent maneuverability. Quick blade position changes can be made.

Infinite speed selection. Infinitely variable ground speeds, from 0 to 6.5 mph (0-10.5 km/h), allow precise matching of machine speed to your application. Ground speed can be reduced without slowing engine rpm, so hydraulic power remains high and response time remains fast.

Automatic load sensing. As a load increases and engine rpm lessens, the transmission automatically reduces ground speed to

match load changes. This feature works at all throttle settings, providing full drawbar pull even at reduced engine speed.

Dynamic braking. Positive speed reduction is provided on slopes. When shifted to neutral, oil flow between the pump and motor is blocked. The crawler stops without use of the service brakes.

Efficiency. Overall, hydrostatic drive is more efficient in delivering horsepower to the tracks than systems that use torque converters. The greatest efficiency advantages are in the 1.5 to 3.5 mph (2.4 to 5.6 km/h) range, the main work speed range of a crawler dozer.

Simplicity. Hydrostatic drive design uses, on the average, 150 fewer parts than the design of an ordinary drive system. Fewer parts mean increased reliability. Some of our hydrostatic drive crawlers have accumulated more than 35,000 hours of use without any major transmission repairs.

FORESTRY APPLICATION

The 850B Crawler can be equipped for forestry applications with the addition of limb risers and screens for the rollover protective structure.

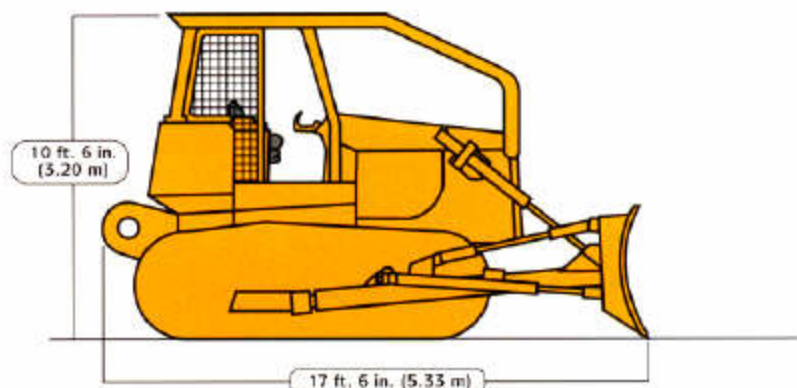

DRAWBAR PULL

Drawbar pull
At 1.2 mph (1.9 km/h) 33,500 lb. (149 kN)
At 2.0 mph (3.2 km/h) 21,000 lb. (93 kN)

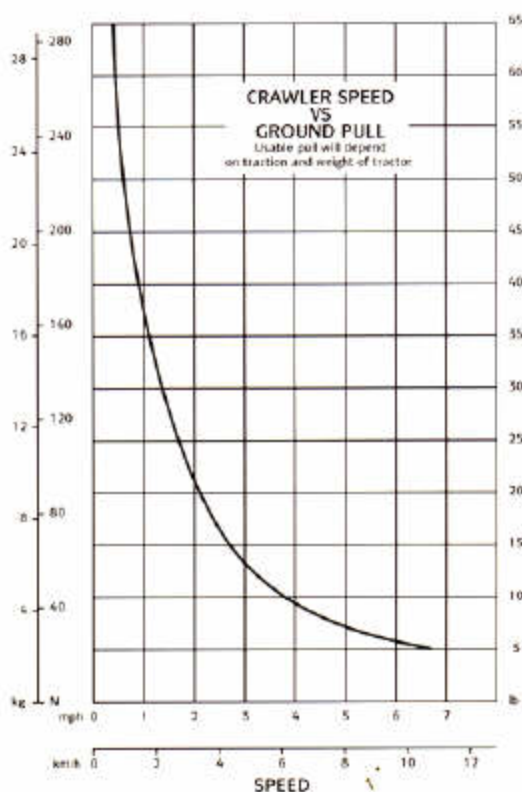

DIMENSIONS*

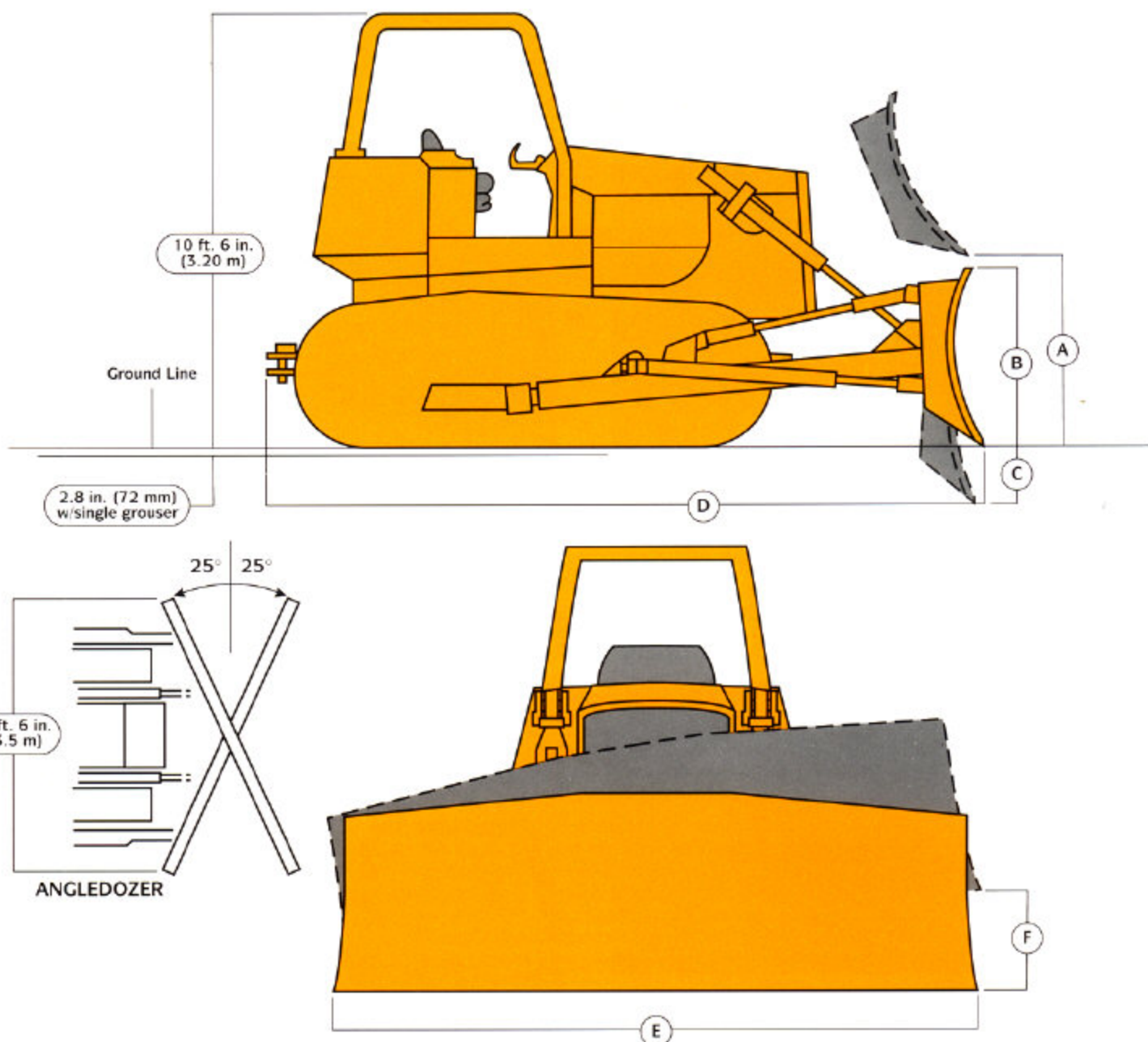

*Drawing based on 850B with 6540 Angledozer

DOZER SPECIFICATIONS

Blade	Blade Capacity per SAE J1265		A Blade Lift Height		B Blade Height		C Digging Depth		D Overall Length (Tractor with Blade)		E Overall Width** (Tractor with Blade)		F Maximum Tilt		Weight		Total Operating Weight (Tractor with Blade)	
	yd ³	(m ³)	in.	(mm)	in.	(mm)	in.	(mm)	ft.-in.	(mm)	ft.-in.	(mm)	in.	(mm)	lb.	(kg)	lb.	(kg)
Straight	3.89	2.97	44.5	1130	42	1067	20.6	523	16' 10"	5130	10' 3"	3124	15.0	381	4600	2086	37,515	17 016
Semi U	5.44	4.16	46.5	1181	43	1092	20.2	513	17' 6"	5334	11' 6"	3505	15.0	381	5020	2277	37,900	17 192
Angle	3.77	2.88	44.0	1118	40	1016	17.2	437	16' 10"	5130	12' 8"	3860	13.25	336	5035	2284	37,915	17 198

**Includes cupped end bit

ADDITIONAL STANDARD EQUIPMENT:

Engine:	Less clutch disconnect
Air cleaner, dual-stage aspirated type	Transmission neutral lock with starter safety switch
Air cleaner restriction indicator	Transmission oil cooler
Precleaner	Hydraulics:
Fan guards	Two-spool hydraulic system
Engine coolant -34°F (-37°C)	"O" ring face seal connectors.
Coolant recovery tank	Electrical System:
Blower fan	Master electrical disconnect switch
Trash resistant radiator	Horn
Oil to water engine oil cooler	Winch drive
Power Train:	Reverse warning alarm
Dual-path hydrostatic transmission	

Operator's Station:	Front pull hook
Canopy (ROPS) with seat belt	Front idler shields
Adjustable suspension seat	Heavy-duty, hinged grille plate
Adjustable armrests	Lockable toolbox
Horn	Muffler, self-draining with eliminating external rain cap
Pushbutton starting	Tilt cylinder hose protection
Key switch	Vandal protection
Hourmeter	Tracks:
Voltmeter	Dura-Trax sealed and lubricated chain
Interior mounted rearview mirror	24-in. (610 mm) grouser shoes
Overall Vehicle:	
Heavy-duty bottom guards, front and rear	
Lower engine side shields	

OPTIONAL OR SPECIAL EQUIPMENT WITH WEIGHTS:

(Add these weights to SAE standard equipment operating weights to obtain total operating weights.)

	lb.	kg
Batteries (two 12-volt) cold-cranking capacity @ 0°F (-18°C) 925 amps, reserve capacity 180 min. each	18	8
Cab with pressurizer, heater and 50-amp alternator	400	182
Air conditioner	109	49
Windshield wiper	3	1
Cold weather starting aid	4	2
Cupped end bits	10	4
Dozers (included in total operating weight)		
6545 straight dozer	-400	-180
Semi U dozer	-15	-7
*6540 Angledozer	0	0
Disconnect clutch	-20	-9
* Drawbar, fixed	270	122
Engine coolant heater	2	1
Fan, reversible	40	18
Fire extinguisher	6	3
Hydraulics:		
Hydraulic lines to rear	4	2
Hydraulic valve, third function	11	5
Selector valve and lines to rear	14	6
Lights, two front, one rear, halogen	7	3
Oil sampling test kit	2	1

	lb.	kg
Perforated hood	-10	-5
Protection items:		
Brush screen, heavy-duty third-post type	275	125
Brush screens, regular-duty	72	33
Guards, lift cylinder	44	20
Guards, final-drive seal	38	17
Guards, tank protection	650	295
Limb risers	353	160
* Perforated engine enclosure	41	18
Perforated engine enclosure, heavy-duty	156	70
Rear screen	50	23
Roof extension	475	215
Radiator sand shield	25	11
Rock guard, center section	259	118
Tracks:		
Dura-Trax sealed and lubricated chain w/split master link		
20-in. (510 mm) grouser shoes	-578	-263
22-in. (560 mm) grouser shoes	-283	-129
** Dura-Trax sealed chain	0	0
* Included in operating weight		
** See your John Deere dealer for further information.		

THE JDAdvantEDGE

JDAdvantEdge is a wealth of support programs, parts systems and dealer resources, all designed to give you the edge. This package of special benefits is a major reason why John Deere offers the "best value" for your equipment dollar.

Best parts support—Twelve regional parts depots in North America and others around the world put parts support near your job no matter where in the world it is.

A computerized FLASH™ parts locating system linking these depots to dealerships can find out-of-stock parts in a hurry and get them into your hands fast. Usually within 24 hours.

Best service backup—Dealer service technicians are regularly schooled, at our modern facility in Davenport, Iowa, or by professionals in the field, to diagnose quickly and repair efficiently.

If they are stumped, a phone call to DTAC (Dealer Technical Assistance Center) puts them in touch with a staff of pros at the factory who help them find a solution quickly.

Best dealers—Your John Deere dealer is an important contributor to the JDAdvantEdge. He or she is committed to being the best equipment supplier you can work with.

This is a dollars-and-cents commitment in parts inventory, in service facilities, in field service trucks. It's a sweat and blood commitment in dedicated, skilled and highly trained and motivated personnel in each and every department at the dealership.

But what sets John Deere dealers apart from all the rest is something more, a factor somewhat difficult to measure . . . a caring attitude, and a sincere desire to be the best at meeting the needs of each individual customer.

John Deere Finance Plans—Whether you rent, lease or buy John Deere equipment, your dealer can explain the John Deere options available. One-stop options that let you free up operating capital, keep other lines of credit open. More solid benefits of the JDAdvantEdge.

Best protection—In addition to the new equipment warranty that meets or exceeds the competition, SECURE® extended coverage, an optional service product for John Deere equipment, is available for repair coverage after the warranty concludes. Full machine or power train coverage is available for a variety of time periods to meet your needs. Consult your dealer for availability and details.

Net engine power is with standard equipment including air cleaner, exhaust system, alternator, and cooling fan, at standard conditions per SAE J1349 and DIN 6270B, using No. 2-D fuel at 35° API gravity. No derating is required up to 10,000 feet (3050 m) altitude. Gross power is without cooling fan.

Specifications and design subject to change without notice. Wherever applicable, specifications are in accordance with SAE standards. Except where otherwise noted, these specifications are based on a unit with rollover protective canopy, 24-in. (610 mm) grousers, engine enclosure, drawbar, front pull hook, full fuel tank, and 175-lb. (79 kg) operator and standard equipment.

