



510B BACKHOE LOADER



Model shown may include options

ENGINE PERFORMANCE

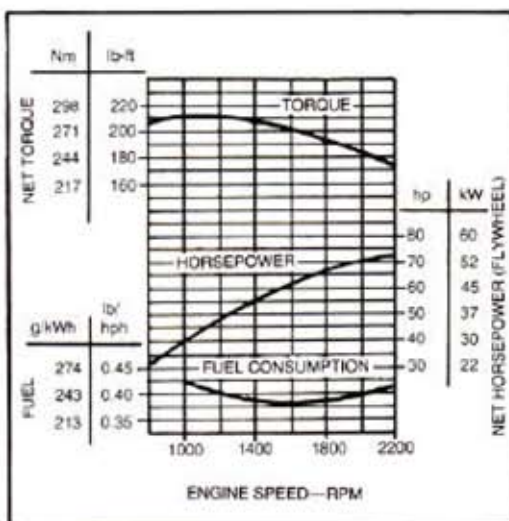

FEATURES

- 70 SAE net hp (52.2 kW)
- Backhoe digging depth (ICED) 15 ft. 6 in. (4.72 m)
- Utilized frame
- Isolated engine and operator's station
- Walk-in front entry
- Designed for quietness
- Closed-center hydraulic system
- Weight distributed for working stability
- Self-adjusting manual hydraulic wet-disk brakes
- ▲ Offset driveshaft for better ground clearance
- Inboard planetary final drives
- Transaxle 1st and 2nd collar shift, 3rd and 4th synchronized
- Full power-shift reverser
- Torque converter
- Single-lever loader control
- Two-lever backhoe control
- Two-lever stabilizer control
- Multi-adjustable swing-around seat

- Hydrostatic power steering
- Built-in ROPS/FOPS
- Soundproofed cab w/integral ROPS/FOPS
- Vandal protection w/built-in locks

ADD VERSATILITY WITH:

- Extendable dipperstick
- ▲ Mechanical front-wheel drive
- ▲ Wet clutch—engage on the go

510B BACKHOE LOADER SPECIFICATIONS

(Specifications and design subject to change without notice. Wherever applicable, specifications are in accordance with ICED and SAE Standards. Except where otherwise noted, these specifications are based on a unit equipped with 19.5L-24, 10 PR, R4 rear tires; 11L-16, 12 PR, F3 front tires; 1.3-cu.-yd. (1.00 m³) loader bucket; 24-in. (610 mm) high-capacity backhoe bucket; ROPS/FOPS; full fuel tank and 175-lb. (79 kg) operator.)

Power (@ 2200 engine rpm):	SAE	DIN
Gross	76 hp (56.7 kW)	
Net	70 hp (52.2 kW)	74 hp (54.4 kW)

▲ Net engine power is with standard equipment including air cleaner, exhaust system, alternator and cooling fan. Gross power is without cooling fan. Power ratings are at standard conditions per SAE J1349 and DIN 70 020.

Engine: John Deere 4-cylinder valve-in-head diesel, 4-stroke cycle
 Bore and stroke 4.19×5.0 in. (106×127 mm)
 Displacement 276 cu. in. (4 524 L)
 Compression ratio 16.2 to 1
 Maximum torque @ 1100 rpm 210 lb.-ft (285 Nm) (29.2 kg-m)
 NACC or AMA (U.S. Tax) horsepower 28
 Main bearings 5
 Lubrication Pressure system w/full-flow filter and cooler
 Cooling Pressurized thermostat and fixed bypass
 Fan Suction
 Air cleaner Dry
 Electrical system 12-volt
 Alternator 51 amps w/cab, 35 amps regular

Torque Converter:
 Single stage, dual phase, overrunning stator, 11-in. (280 mm) diameter, stall ratio 2.8:1.

Reverser:
 Modulated, full power shift with multiple wet-disk clutches. Reverser operating lever at left of steering wheel.

Transmission:
 Manual shift with first and second speeds having sliding collar engagement and third and fourth speeds engaged with cone-type synchronizers. Single shift lever, floor mounted.

▲ Travel Speeds:	Forward		Reverse	
	mph	km/h	mph	km/h
Gear 1	0-3.5	5.6	0-4.0	6.4
2	0-7.4	11.9	0-8.6	13.8
3	0-13.5	21.7	0-15.7	25.3
4	0-22.1	35.6	0-25.7	41.4

Final Drives Planetary, inboard

Service Brakes:
 Manual hydraulic, applied with separate pedals; hydraulically equalized when both pedals are depressed. Wet disks and facings are fully enclosed and self-adjusting.

Steering: Hydrostatic power
 Steering, regular axle:
 Turning radius (brake applied) 10 ft. 3 in. (3.12 m)
 Clearance circle 29 ft. 6 in. (9 m)
 Steering wheel turns, left to right 2.9
 right to left 3.9

▲ Mechanical front-wheel drive
 Turning radius (brake applied) 12 ft. 10 in. (3.91 m)
 Clearance circle 30 ft. 6 in. (9.30 m)
 Steering wheel turns, left to right 2.9
 right to left 3.9

Hydraulic System: Closed-center (variable flow, constant pressure)
 Pressure 2500 psi (17 238 kPa) (175.8 kg/cm²)
 Pump 8 radial pistons, variable flow
 Flow @ 2200 psi (15 170 kPa) (154.7 kg/cm²) 35 gpm (2.21 L/s)
 Filter, return oil 10 micron, steel-enclosed replaceable element
 Screen, pressure oil 50/in. (20/cm) mesh

Hydraulic Cylinders:	Bore		Stroke		Rod	
	In.	(mm)	In.	(mm)	In.	(mm)
Loader boom (2)	3.5	89	30	762	1.75	44
Loader bucket (1)	4.0	102	24.4	620	2.0	51
Backhoe boom (1)	5.0	127	42.7	1085	2.5	64
Backhoe crowd (1)	4.5	114	34.5	876	2.25	57
Backhoe bucket (1)	3.5	89	27.4	696	2.25	57
Backhoe swing (2)	4.0	102	9.5	241	2.0	51
Backhoe extendable dipper (1)	2.5	64	60	1524	1.25	32
Backhoe stabilizers (2)	4.0	102	20.3	516	2.0	51
Steering (1) regular axle	2.0	51	9.5	241	1.0	25.4
▲ Steering (1) MFWD	2.0	(51)	12.6	(320)	2.0	(51)

Tires:	Front	Rear
	11-16, 12 PR, F3	19.5L-24, 10 PR, R4
	14.5/75-16.1, 10 PR, F3	19.5L-24, 12 PR, R4
		21L-24, 10 PR, R4

▲ Mechanical front-wheel drive 12.00-16.5, 8 PR, R4

Wheel Treads:
 Front 68 in. (1727 mm)
 Rear 66 in. (1675 mm)
 ▲ MFWD 68 in. (1727 mm)

Wheelbase 83 in. (2110 mm)
 ▲ MFWD 83.3 in. (2116 mm)

Axle Ratings: (SAE J43)
 Front 10,500 lb. (4760 kg)
 Rear 13,400 lb. (6080 kg)

Capacities:	U.S.	Liters
Fuel tank	23 gal.	87.1
Engine coolant	17 qt.	16.1
Engine oil including filter	9 qt.	8.5
Torque converter and reverser system	14 qt.	13.2
Transaxle and hydraulic system	21 gal.	79.5

Additional Standard Equipment:
 Alternator, 35 amp, w/transistorized voltage regulator
 Backhoe transport lock
 Cast-in-counterweight front axle
 Differential lock, foot-engaged collar
 Electric automatic destroke for hydraulic pump
 Electric combination tachometer/hourmeter
 Electric shutoff on diesel injection pump
 Emergency/parking brake
 Foot and hand throttles
 Fuel tank contaminant sump w/easy access drain
 Gauges for:
 Engine coolant temperature
 Fuel tank level
 Hydraulic/transmission oil temperature

Horn
 Hydraulic lockouts for stabilizers
 Indicator lights:
 Alternator
 Engine oil pressure
 Parking brake
 Turn signals
 Key switch controls for electrical circuits
 Lights, road operation and work site
 Loader bucket automatic hydraulic, self-leveling
 Loader bucket level indicator
 Multiple-fuse-protected electrical system
 Oil-to-air cooler for hydraulic system and transaxle
 Oil-to-air cooler for torque converter and reverser
 Pushbutton safety start switch
 Rear fenders
 Rear reflectors
 Restriction indicator for engine air cleaner
 ROPS/FOPS with roof and seat belt
 Steps and handholds

SAE Operating Weight 15,300 lb. (6940 kg)

▲ Indicates change since last printing.

510B BACKHOE LOADER SPECIFICATIONS

Operating Information

BACKHOE:

Operator control	Two levers
Digging depth (ICED):	
Maximum	15 ft. 8 in. (4.78 m)
2-ft. (610 mm) flat bottom	15 ft. 6 in. (4.72 m)
8-ft. (2440 mm) flat bottom	14 ft. 5 in. (4.40 m)
Swing arc	180 degrees
Lifting capacity:	
Boom lifting, dipper extended	2500 lb. (1135 kg)
Dipper lifting, boom @65 deg.	5000 lb. (2270 kg)
Digging force:	
Bucket cylinder in power-dig position	10,200 lb. (45.4 kN) (4627 kg)
Crowd cylinder	7700 lb. (34.2 kN) (3493 kg)
Reach:	
From center of swing mast	19 ft. 2 in. (5.84 m)
From center of rear axle	22 ft. 2 in. (6.75 m)
Loading height, truck-loading position	10 ft. 10 in. (3.30 m)
Transport height	12 ft. (3.65 m)
Bucket rotation	Adjustable for 123, 127 or 155 degrees
Bucket positions	12 or 20 degrees rollback or 6 degrees forward

STABILIZERS:

Operator control	Two levers
Transport width	7 ft. 8 in. (2.34 m)
Spread in operating position	9 ft. 10 in. (3 m)
Angle rearward	13 degrees

EXTENDABLE DIPPER OPTION:

Operator control	Right foot treadle
Digging depth, 2-ft. (610 mm) flat bottom	
Extended	20 ft. 8 in. (6.30 m)
Retracted	15 ft. 6 in. (4.72 m)
Reach from center of swing mast	
Extended	24 ft. (7.30 m)
Retracted	19 ft. (5.80 m)
Loading height, truck-loading position	
Extended	13 ft. 10 in. (4.22 m)
Retracted	11 ft. 4 in. (3.45 m)
Digging force, crowd cylinder	
Extended	4935 lb. (21.9 kN) (2236 kg)
Retracted	7570 lb. (33.7 kN) (3434 kg)

Optional or Special Equipment:

- Altitude-compensating engine turbocharger
- Automatic return-to-dig
- Auxiliary hydraulic valves and circuit for loader and backhoe
- Bolt-on teeth for loader bucket
- Cab with:
 - 51-amp alternator
 - Fabric-covered swivel seat, suspension or non-suspension
 - Front defroster fan
 - Front and rear wipers
 - Integral ROPS/FOPS
 - Standard heater
- Cold-weather starting aid, remote mounted
- Engine coolant heater
- Extendable dipperstick for backhoe
- Fire extinguisher
- Front frame-mounted counterweight
- Heavy-duty batteries
- ▲ Mechanical front-wheel drive
- Rear defroster fan
- Rear-view mirror, inside mounted, curved, heavy-duty
- Rear wheel spacers for tire chain clearance
- Reverse warning alarm
- Reversible stabilizer pads
- Ripper tooth for backhoe, 24 in. (610 mm)
- Rotating beacon light
- Special loader bucket for bolt-on teeth or auxiliary cutting edge
- Swivel seat, vinyl covered, suspension or non-suspension
- SMV emblem
- 3-in. (76 mm) seat belt
- Toolbox

LOADER:

Operator control	Single lever
Rollback at ground level	40 degrees
Breakout force	9200 lb. (40.9 kN) (4173 kg)
Digging depth below ground, bucket level	4 in. (100 mm)
Lifting capacity, full height	6180 lb. (2810 kg)
Height to bucket hinge pin, max	11 ft. (3.35 m)
Bucket dump angle, max.	50 degrees
Dump clearance, bucket @ 45 degrees	8 ft. 9 in. (2.67 m)
Reach at full height, bucket @ 45 degrees	30 in. (762 mm)
Raising time to full height	4.5 sec.
Bucket dump time	1.0 sec.
Bucket lowering time (power down)	3.0 sec.

Loader:	Width In. (mm)	BUCKETS Struck Capacity		Heaped Capacity	
		Cu. Ft.	(m ³)	Cu. Yd.	(m ³)
	92 (2340)			1.3 (1.00)	
Backhoe:				Cu. Ft.	(m³)
Standard duty	12 (305)	2.6 (0.07)		3.0 (0.08)	
	16 (406)	3.7 (0.10)		4.5 (0.13)	
	18 (457)	4.2 (0.12)		5.1 (0.14)	
	24 (610)	5.9 (0.17)		7.5 (0.21)	
	30 (762)	7.5 (0.21)		10.0 (0.28)	
Heavy duty	36 (914)	7.5 (0.21)		10.0 (0.28)	
	18 (457)	4.2 (0.12)		5.1 (0.14)	
	24 (610)	5.9 (0.17)		7.5 (0.21)	
	30 (762)	7.5 (0.21)		10.0 (0.28)	
High capacity	24 (610)	7.2 (0.20)		8.8 (0.25)	
	36 (914)	11.2 (0.32)		14.5 (0.41)	
Ejector	24 (610)	4.6 (0.13)		5.7 (0.16)	

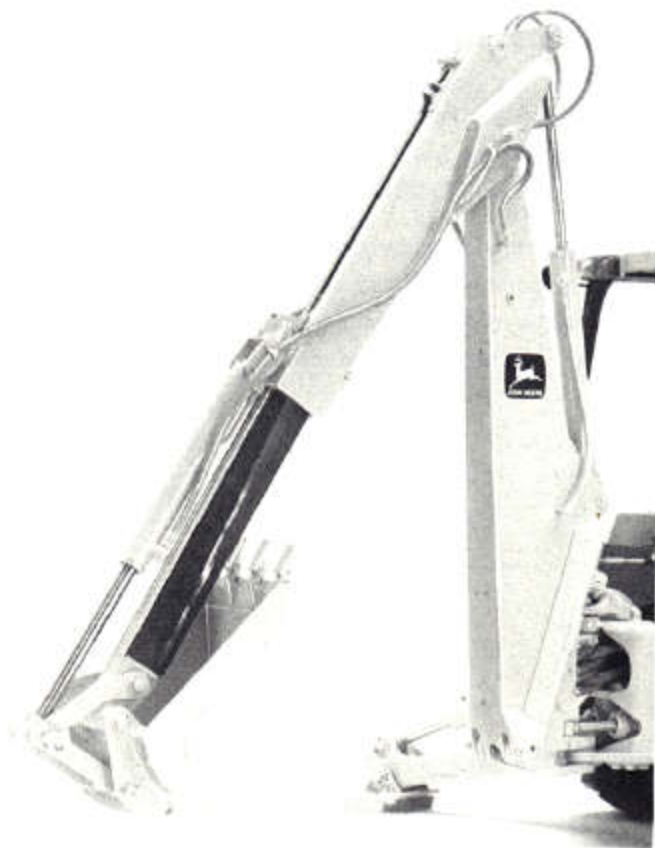

510B BACKHOE LOADER DIMENSIONS

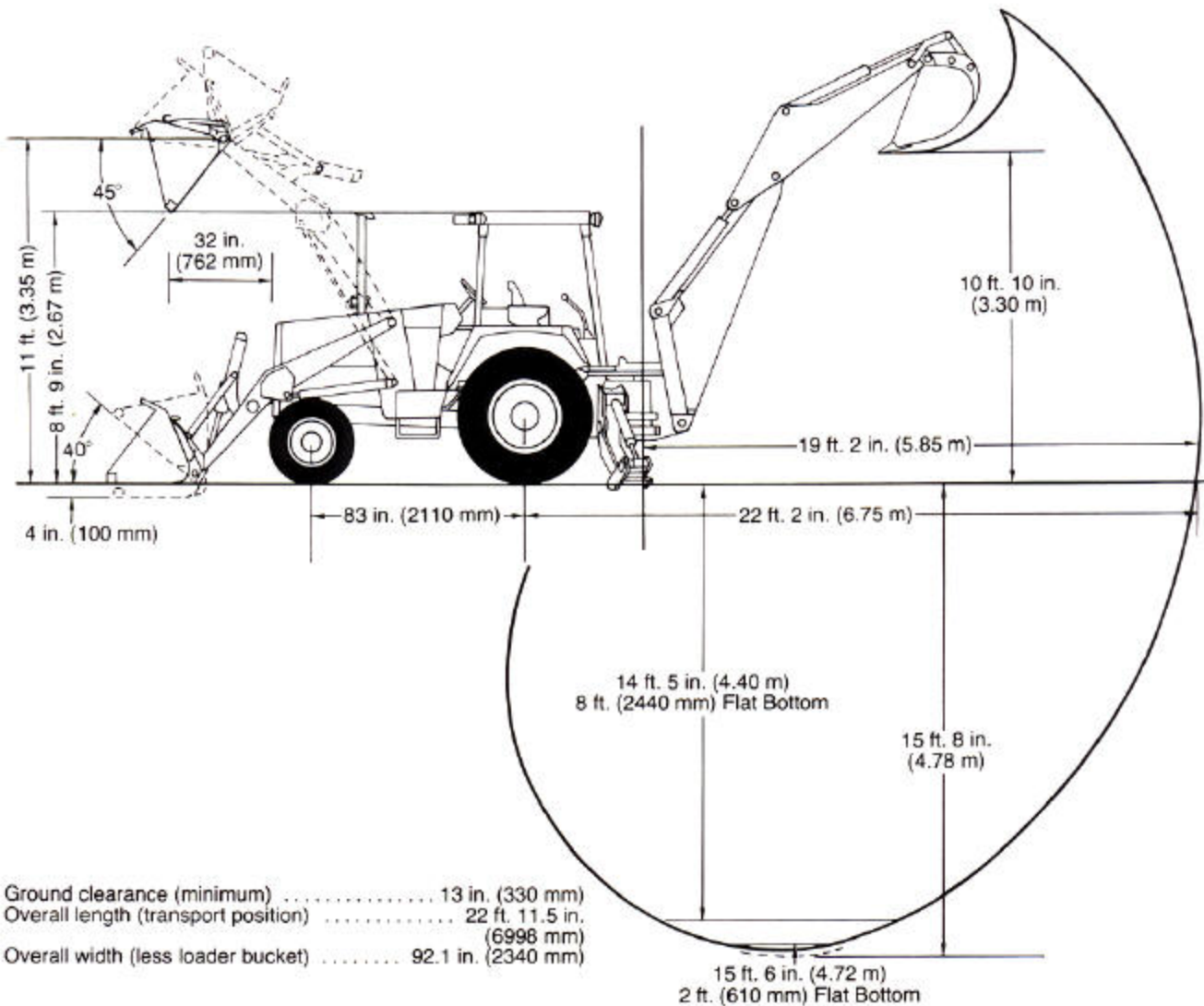

Ground clearance (minimum) 13 in. (330 mm)
 Overall length (transport position) 22 ft. 11.5 in. (6996 mm)
 Overall width (less loader bucket) 92.1 in. (2340 mm)

510B BACKHOE LIFT PER SAE J31

▲ (Lift capacities are 87% of the maximum lift over the rear)

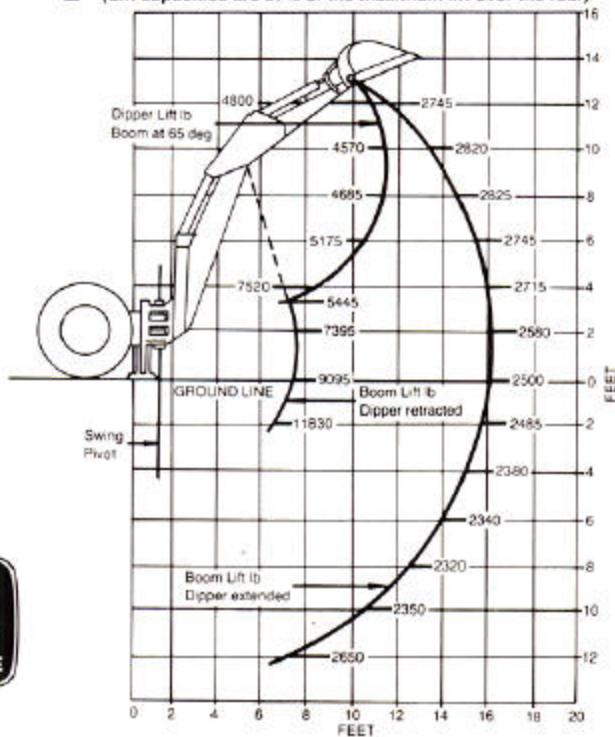

510B BACKHOE LIFT PER SAE J31

(Lift capacities are 87% of the maximum lift over the rear)

