

BOMAG

Refuse Compactor BC972RB, BC1172RB



- High pushing power (199 lbs/hp)-BC972RB and (234 lbs/hp)-BC1172RB
- Highest compaction densities
- Efficient fuel consumption rate
- Quiet operation - quiet cab
- Stable and safe operation on slopes
- High compressive demolition force



BC972RB, BC1172RB



High-performance diesel engine meets emission regulations up to and beyond the year 2002.

Engine cooling air intake over 14 feet above grade for cleanest air quality.

Ergonomically designed operator's compartment, heated and air-suspended seat for maximum productivity.

Adjustable scraper bars keep wheels free of debris for maximum tooth penetration.

± 15° oscillation ensures full ground contact on irregular terrain for maximum compaction.

The frame's sealed tub design eliminates the need for belly pans, reduces the risk of fire from debris build up in engine compartment.

Massive oscillating, articulating center joint - bolted on for easy servicing.

17.1 foot wide by 7.3 foot tall landfill dozer blade with replaceable cutting /wear edges

■ *These models are designed specifically for landfill operation...*

In spite of alternative methods of waste elimination, sanitary landfill sites are still the primary method of refuse disposal in use today. Modern, well-engineered and managed landfills are still a vital part of the global waste disposal concept.

To obtain the most effective use of landfill space, a high performance refuse compactor, designed specifically for the extreme demands imposed by landfill conditions is needed. Proper and maximum compaction is key to ensuring that refuse is deposited at the highest possible densities. Achieving this results in the reduction of material settlement and water penetration, improving the overall running surface of the landfill and decreasing the dangers of fire

and landfill gas emissions. Improving compacted material densities through the reduction of air voids results in extended operating life of a landfill. High refuse density makes both environmental and economic sense.

Refuse is a mixture of varying different materials including large household and business waste, food, sludge, dust, construction materials and many other items. In order to compact these materials efficiently, the compactor must be capable of dealing with the differing demands and varying challenges they present.

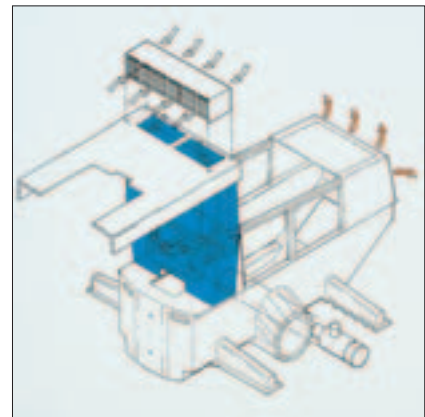

A BOMAG exclusive: utilizing the cleanest air possible from over 14 feet above grade

Normal operating conditions of a landfill site place extreme demands on the drive system of a refuse compactor. Pushing and spreading waste requires maximum torque and power; compacting in either forward or reverse direction on the working face demands highest tractive effort. The BC972RB/ BC1172RB combines the efficient engine horsepower utilization of a hydrostatic drive system with 4 independent wheel drive motors to meet the challenges faced by a refuse compactor and to provide greater tractive effort regardless of operating conditions.



4-wheel hydrostatic drive system is capable of 100% gradeability, 45° slopes

Improved compaction performance and operating ease

■ Handling is Easier and Safer

- Excellent all-around cab visibility with tinted safety glass.
- Heated and air-suspended seat makes operation fatigue-free and safe.
- Simple and clear control layout allows unfamiliar operators to work safely.
- Load Sensing System provides smoother and lighter steering and blade control.
- Joystick steering control
- Cab noise levels are lowest in the industry, less than 75 dBA.
- The ventilation system draws air through a fine filter and slightly pressurizes the cab to prevent entry of polluted air.
- The BC972RB has a powerful water-cooled diesel engine with 511 hp output at 2100 rpm. The BC1172RB has an additional 25 hp pushing the rating to 536 hp output at 2100 rpm.
- Air for cooling and combustion is taken from a height of over 14 feet above grade. At this height the air is relatively free from dirt and dust and is cleaned by a fine mesh filter before entering the engine compartment.
- The sealed engine compartment maintains a positive pressure to prevent entry of debris.



Ergonomic control layout including joystick steering control.



- The Deutz BF8M1015C series engine with 968 C.I.D. and turbocharger will meet emission regulations until well past the year 2002 and gives high torque at low revolutions.
- Engine power on the BC972RB/ BC1172RB drives a hydrostatic system with independent 4 wheel drive motors.



Featuring...



More efficient utilization of available engine horsepower through the BC972/1172RB's hydrostatic drive system

Compaction wheel design - key to maximum densities

Achieve Maximum Productivity:

Compaction wheels are the refuse compactor's tools. They shred, demolish and compact the waste. Heavy weight alone cannot guarantee maximum compaction densities, optimum performance can only be achieved in conjunction with the appropriate wheel design and cleaning system.

- BC972RB/BC1172RB wheels have polygonal disk segments and one piece cast, high wear life teeth as standard equipment.
- High static weight, four-wheel contact provided by the oscillating joint and proven compaction advantage of the wheel design ensures maximum compaction performance.
- Two wire cutters per wheel protect against wire wrap-around and subsequent damage to seals or other components.



Only BOMAG has $\pm 15^\circ$ oscillation movement between front and rear frames.

- A massive slew-ring oscillation joint allows $\pm 15^\circ$ movement, ensuring full four-wheel contact for maximum traction and compaction.
- Hydrostatic drive systems need no torque converter and provide up to 15% greater efficiency compared to conventional hydrodynamic drives.



The sealed tub design protects all drive components as well as aids in keeping the engine compartment clean and debris free.



Only BOMAG has polygonal disk wheels with adjustable scraper bar assemblies



By using the latest engine technology, the Deutz engine will meet and exceed all emission requirements

With these features and many more, it's easy to see why these models maintain a high residual value while delivering lower lifetime operating costs.



Easy access to the engine compartment and hydraulic components area through hinged access doors.

Reducing operating costs increases profits

Less Service & Maintenance:

Routine maintenance and breakdowns affect machine availability and operating costs of a refuse compactor. The BC972RB/BC1172RB have been designed to extend maintenance intervals and reduce downtime and repair costs.

- Only BOMAG, with engine cooling air intake over 14 feet high, can reduce radiator cleaning intervals from five times a week to approximately once a week for reduced maintenance costs.
- The ROPS is an integral part of the frame and channels cooling air to the engine.
- Access to the engine compartment is easy using the hinged access doors.
- The hatches at the front and rear of the machine provide easy access to the engine and hydrostatic service points.
- All components are easily accessible for maintenance.
- All drive components are protected from damage within the sealed frame.
- The BC972RB/BC1172RB's sealed tub design eliminates the need for belly pans.
- Central lubrication system services 13

front and rear frame-located grease fittings once each operating hour.

- The blade lift cylinder spherical bearing is a teflon material requiring no daily maintenance.
- The BOMAG oil filter system extends hydraulic oil change intervals up to 2000 operating hours.
- Hydrostatic drive is virtually wear-free.
- The hydrostatic drive's automatic performance control ensures that the engine is providing the optimum power output at all times, reducing yearly operating costs while protecting the engine from overload.
- The Load Sensing System of the blade and steering circuits uses only as much hydraulic oil as is needed and can save up to 80 hp over conventional fixed displacement systems.
- The Deutz diesel engine is powerful and reliable.
- 24 V electrical system reduces load on electrical components.
- The center articulation joint, designed to withstand extreme conditions, provides $\pm 40^\circ$ steering angle.

Standard Features

- ✓ Engine air intake at 14.44' height
- ✓ Adjustable scrapers in front and behind each wheel
- ✓ Polygonal compaction wheels with exchangeable pad feet
- ✓ Two (2) wire cutters at each wheel
- ✓ Protection of all drive components by a fully enclosed engine bay compartment
- ✓ Fully automatic load limit control
- ✓ 4 wheel independent hydrostatic drive
- ✓ ROPS
- ✓ Dozer blade 17.1'
- ✓ Access step right/left
- ✓ Noise insulated cab
- ✓ Vibration isolated cab mounting
- ✓ Pressurized Cab
- ✓ Cab heating & air conditioning
- ✓ Sliding windows right/left
- ✓ Tinted safety glass
- ✓ Air suspension seat with seat belt in compliance with ISO 6683
- ✓ Head rest
- ✓ Heated seat
- ✓ Seat mounted controls for dozer blade, travel actuation and steering
- ✓ Sun shade
- ✓ Rear view mirror outside and inside
- ✓ Joystick steering
- ✓ Windshield wiper and washer system at front and rear
- ✓ Audible back-up alarm system
- ✓ Warning horn
- ✓ Electronic monitoring board with engine shut-down
- ✓ Rotary beacon
- ✓ Heatable outside mirrors
- ✓ Indicators and gauges
- ✓ AM/FM radio with stereo cassette
- ✓ 24V electrical system
- ✓ Battery disconnect switch
- ✓ Heavy duty batteries
- ✓ Alternator 80 A
- ✓ Working lights front/rear
- ✓ Automatic central lubrication system
- ✓ Fuel priming pump
- ✓ 3-stage fuel filtering system

(Continued)

Technical Specifications

BC972RB, BC1172RB

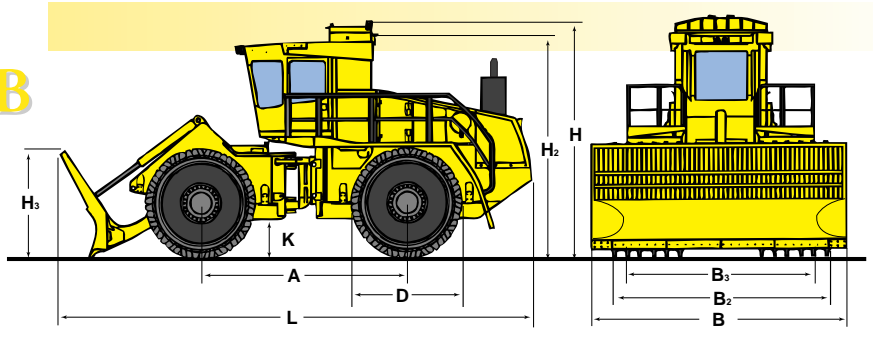

Shipping dimensions in cubic feet (m ³)	
BC972RB	with dozer blade 7613.8 (215.6)
BC1172RB	7613.8 (215.6)

Standard Features (Continued)

- Dry air filter
- Cold starting system
- Hydraulic steering
- Wear control in the hydraulic oil circuit
- Replaceable blade cutting edges
- Towing hooks front/rear
- Interval switch for windshield wipers
- Activated carbon air filtration system
- Rear view camera

Optional Equipment

- Fire extinguisher
- Environmental awareness hydraulic lubricant
- Tool kit
- Hydraulic test kit
- Electric service tool kit
- Vacuum pump for hydraulic
- Protective ventilation system
- Special paint

Dimensions in inches (mm)

	A	B	B ₂	B ₃	D	H	H ₂	H ₃	K	L
BC972RB	161.4 (4100)	204.7 (5200)	177.2 (4500)	167.7 (4260)	86.6 (2200)	190.7 (4845)	173.2 (4400)	87.6 (2225)	30.1 (765)	371.1 (9425)
BC1172RB	161.4 (4100)	204.7 (5200)	177.2 (4500)	167.7 (4260)	86.6 (2200)	190.7 (4845)	173.2 (4400)	87.6 (2225)	30.1 (765)	371.1 (9425)

Technical data

		BOMAG BC972RB	BOMAG BC1172RB
Weights			
Operating Weight	lbs (kg)	101,630 (46100)	120,000 (55431)
Axle load rear	lbs (kg)	50,815 (23049)	60,000 (27216)
Axle load front	lbs (kg)	50,815 (23049)	60,000 (27216)
Dimensions			
Rear overhang	in (mm)	99.8 (2535)	99.8 (2535)
Dimensions		see sketch	see sketch
Compaction Wheels			
Width, front/rear	in (mm)	55.1 (1400)	55.1 (1400)
Outer diameter front/rear	in (mm)	86.6 (2200)	86.6 (2200)
Number of teeth, front/rear		72	72
Coverage per wheel	in (mm)	59.8 (1520)	59.8 (1520)
Drive			
Engine manufacturer		Deutz	Deutz
Type		BF8M 1015C	BF8M 1015C
Cooling		Water	Water
Number of cylinders		8	8
Performance ISO 9249	hp (kW)	518 (381)	544 (400)
Speed	rpm	2100	2100
Performance SAE J1349	hp (kW)	511 (381)	536 (400)
Speed	rpm	2100	2100
Electric equipment	V	24	24
Drive system		hydrostatic	hydrostatic
Number of driven wheels		4	4
Dozer Blade			
Height adjustment over ground level	in (mm)	54.1 (1375)	54.1 (1375)
Height adjustment below ground level	in (mm)	2 (50)	2 (50)
Driving characteristics (depending on site conditions)			
Speed (1) forward/reverse	mph (kmph)	0-1.9 (0-3)	0-1.9 (0-3)
Speed (2) forward/reverse	mph (kmph)	0-3.1 (0-5)	0-3.1 (0-5)
Speed (3) forward/reverse	mph (kmph)	0-7.5 (0-12)	0-7.5 (0-12)
Max. gradeability	%	100	100
Brakes			
Service brake		hydrostatic	hydrostatic
Parking brake		mechanical	mechanical
Emergency brake		hydraulic	hydraulic
Steering			
Steering system		oscil., artic.	oscil., artic.
Steering method		hydraulic	hydraulic
Steering angle ±	degrees	40	40
Oscillating angle ±	degrees	15	15
Track radius, inner	in (mm)	120 (3050)	120 (3050)
Capacities			
Fuel	gal (l)	264 (1000)	264 (1000)
Hydraulic oil	gal (l)	156 (590)	156 (590)
Engine oil	gal (l)	11.9 (45)	11.9 (45)

Technical modifications reserved. Machines may be shown with options.

B72H-397 3M503TTWW



2000 Kentville Road • Kewanee, IL 61443
Tel: 309 853-3571 • Fax: 309 852-0350